

ALTRONICS inc

PERFORMANCE ELECTRONICS

POWERQUEST

Touch Screen Control System

POWERQUEST Touch Screen Control System consists of two components (16 Channel- three), the Touch Screen (TS) and the Switch Panel Module (SPM) MAIN and AUX. The PowerQuest system can control the switching of 16 circuits. 6 circuits are predefined and 10 are custom. Each circuit can be fused up to 30 amps. The system should be installed by a certified automotive technician. **Connect GROUND wires first!!!!**

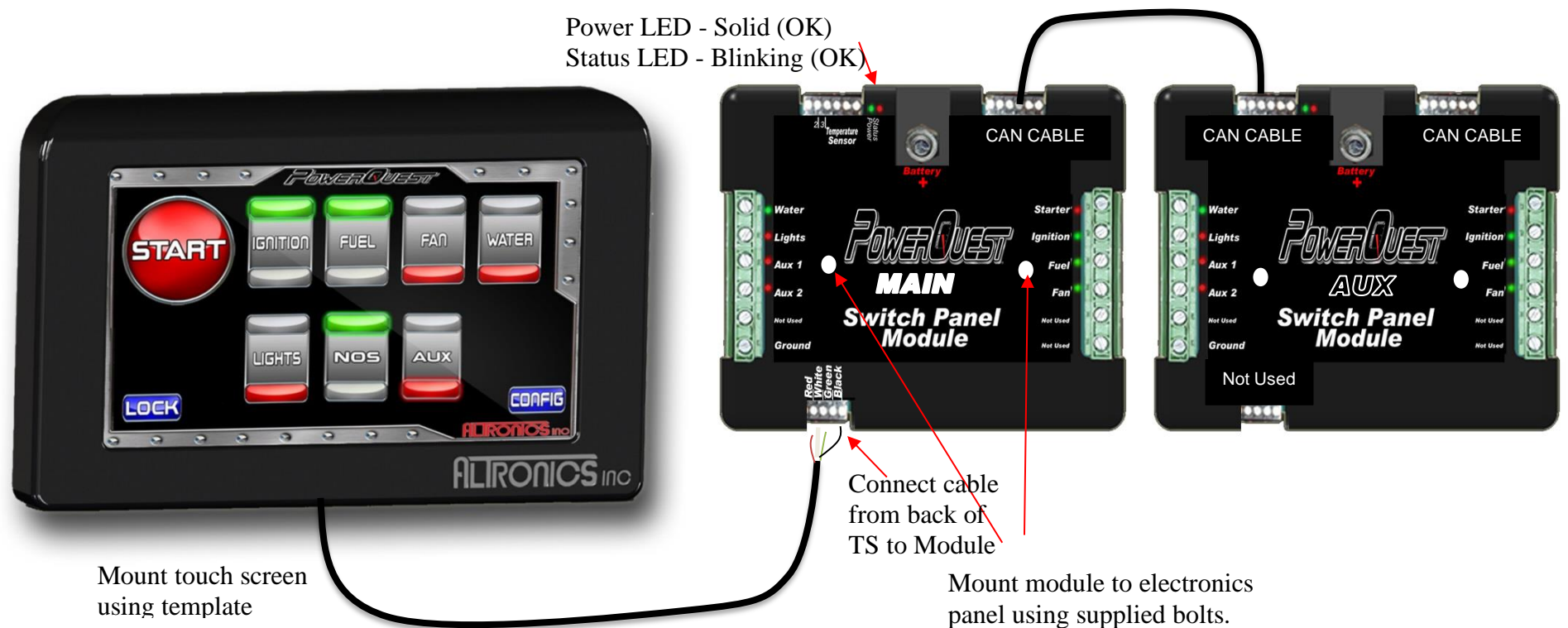

1411 S. Roselle Rd. Schaumburg, IL 60193 Phone (847) 923-0002 Fax (847) 923-0004

www.AltronicsInc.com

WiringSystem:

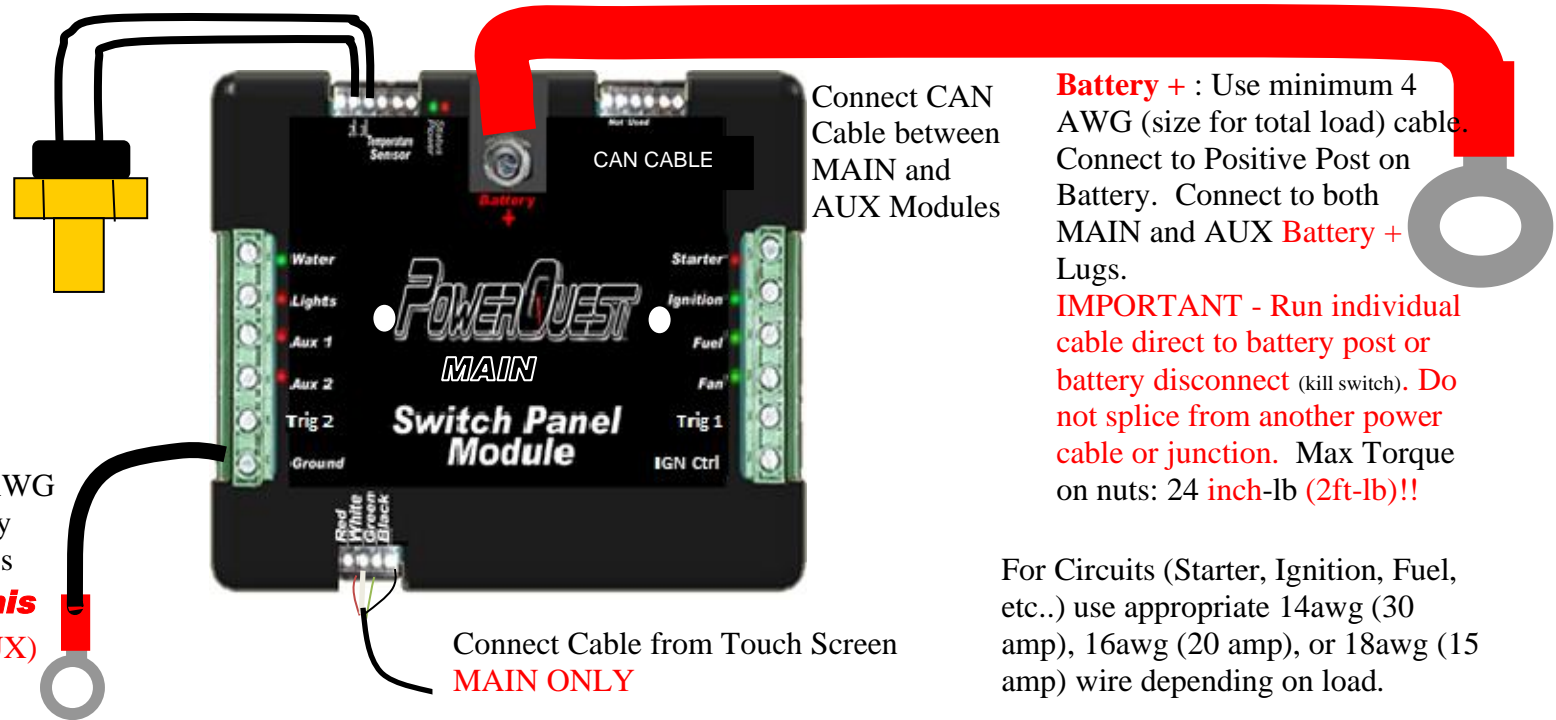

Terminals 2 and 3: Connect to **Temperature** sensor (included). **MAIN ONLY**

Ground Terminal: Use #12 AWG Wire. (Recommend to Battery Negative Post or Good Chassis Ground Point) **Connect this wire first!** (MAIN and AUX)

Connect CAN Cable between MAIN and AUX Modules

Battery + : Use minimum 4 AWG (size for total load) cable. Connect to Positive Post on Battery. Connect to both MAIN and AUX **Battery +** Lugs.

IMPORTANT - Run individual cable direct to battery post or battery disconnect (kill switch). **Do not splice from another power cable or junction.** Max Torque on nuts: 24 **inch-lb (2ft-lb)!!**

For Circuits (Starter, Ignition, Fuel, etc..) use appropriate 14awg (30 amp), 16awg (20 amp), or 18awg (15 amp) wire depending on load.

IGN Ctrl – Connect ignition signal or other switched signal to IGN Ctrl terminal. This input will allow (**Trig enabled (IGN)**) channels to turn on/off when ignition is turned on/off. Also, ignition can control system power up and down if **Ignition/Switch Power** off is enabled in **SETUP** menus (see Configure section) Connect **Ign Ctrl** to both MAIN and AUX modules when used.

Trig1 Trig 2 – This input will allow (**Trig enabled**) channels to turn on/off when Trig 1 or Trig2 signal is turned on/off. Feature must be enabled in **SETUP** menus (see Configure section)



Configure:

System will be Configured with default settings. To change those settings press the “Config” button on the switch panel screen.



Brightness – Sets screen brightness

Sleep – Turns screen off when no user press for sleep time. Press anywhere on screen to turn back on. Can also be controlled by ignition signal.

Security Enable – Activates optional Lock Screen and Manual Sleep.

Enable 16 Ch– Activates second module when installed

Ign/Switch Power – Enables external ignition or switch input into external IGN terminal to control system power up and down (**Sleep**).

Display Amps – Activates displaying current level for each switch channel.

Blue Tooth – Bluetooth setup for BT control, **optional**.

Select Channel- Press to see list of available switch **Channels**, then select channel to modify

Not all features are available for all circuits.

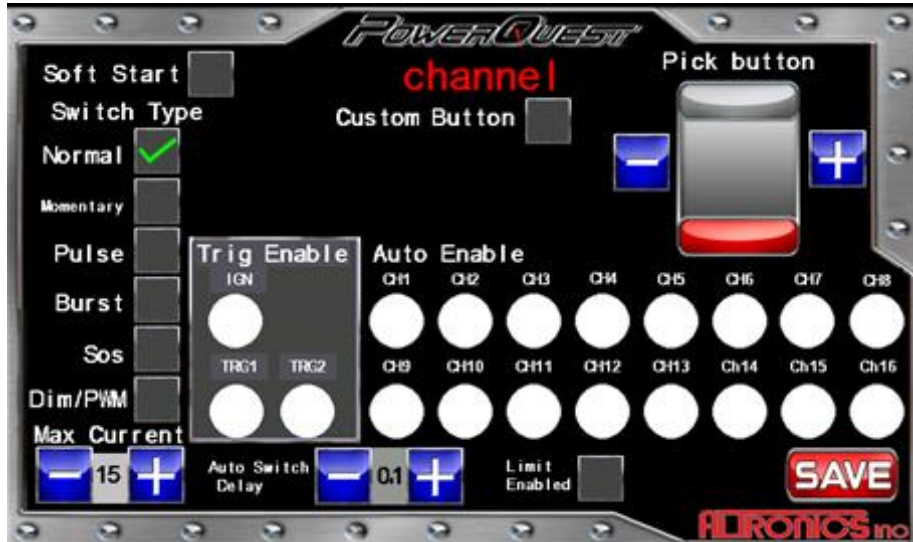

Channel – Displays channel name.

Pick button: Use +/- buttons to cycle thru preset buttons

Custom button: Select to enter custom label for button.

Soft Start: Check box to allow slow increase in current at turn on.

Switch Type: Select switch behavior.

Normal, Momentary, Pulse (turn signal), Burst (high speed pulse, with pause), SOS (distress pulse), Dim/PWM (Select 0-100% power for dimming lights or running motor at different speeds)

Max Current: Select maximum fused amperage for circuit (0-30amps).

Limit Enabled: Check box to limit circuit turn on by temperature settings

Temperature: Select temperature to enable.

Hysteresis: Differential temperature change required to activate.

(Ex: With a 2° hysteresis and a 100° temperature setting the controller will allow the actual temperature to go to 98° before turning off Fan and Pump and back to 100° to turn on again) allow the actual temperature to go to 98° before turning off Fan and



Pump and back to 100° to turn on again)

Auto Enable: Check to enable. Allows switch channel to automatically turn on and off other selected channels when activated/deactivated.

Auto Switch Delay: Time in seconds selected circuit is delayed from turning on if it is Auto Enabled from another channel.

Trig Enable: External control to turn channel on or off. Requires wired connection to IGN (ignition), Trig 1 or Trig 2 terminals on module.

Save: Saves changes and returns to previous Menu.

Lock Screen:



Master Code: On the back of Module (not the touch screen) there is a tag with the systems Master 4 digit program code and a Temporary User Code. You can use the Master code to program your User code. The Master code can always be used to reset User code.

Reset User Code: Use following sequence to program User Code. User code cannot be Master Code or 1234.

- 1) Key in Master Code and press ENTER
- 2) Use Back arrow to delete Master Code from window.
- 3) Key in number USER CODE XXXX and press ENTER
- 4) Press Enter Again

Now User Code is set.

Unlock Screen: Key in User code and press ENTER

SLEEP: Press Sleep to force sleep mode.

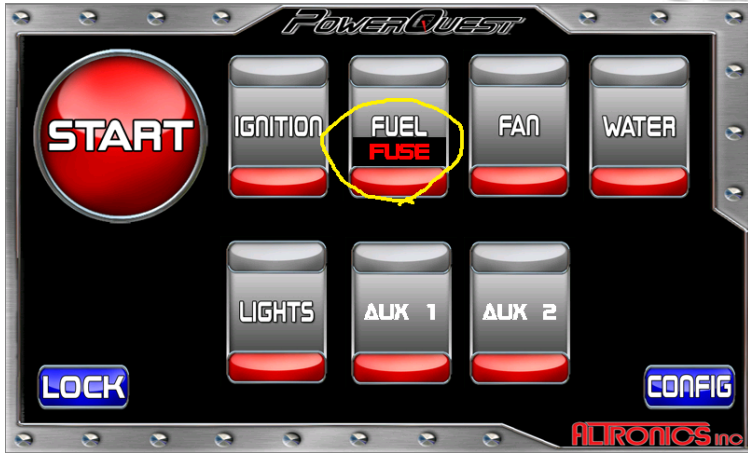

If fuse is tripped Switch Panel circuit button will turn off and “FUSE” message will be shown on button label. Pressing button again will reset fuse.

PowerQuest Demonstration video (www.altronicsinc.com/switch-panels/powerquest-1.html) for more details.

TECHNICAL SUPPORT:

Email: Tech@AltronicsInc.com

When sending a unit in for repair or update: Fill out a “Service Form” which is available from the Technical Support Section of our website-> www.AltronicsInc.com

WARRANTY:

POWERQUEST by **ALTRONICS inc** is warranted for 1 Year against any defect in materials and workmanship from date of purchase. ALL WARRANTIES AND GUARANTEES ARE VOID if the **POWERQUEST** enclosures are opened or altered or if equipment is connected to system that is not supplied or authorized by Altronics Inc.

ALTRONICS inc shall not be liable for injury, consequential, or other types of damages resulting from the use or misuse of the **POWERQUEST**.

POWERQUEST is to be used for off road purposes only!

1411 S. Roselle Rd. Schaumburg, IL 60193 Phone (847) 923-0002 Fax (847) 923-0004

www.AltronicsInc.com

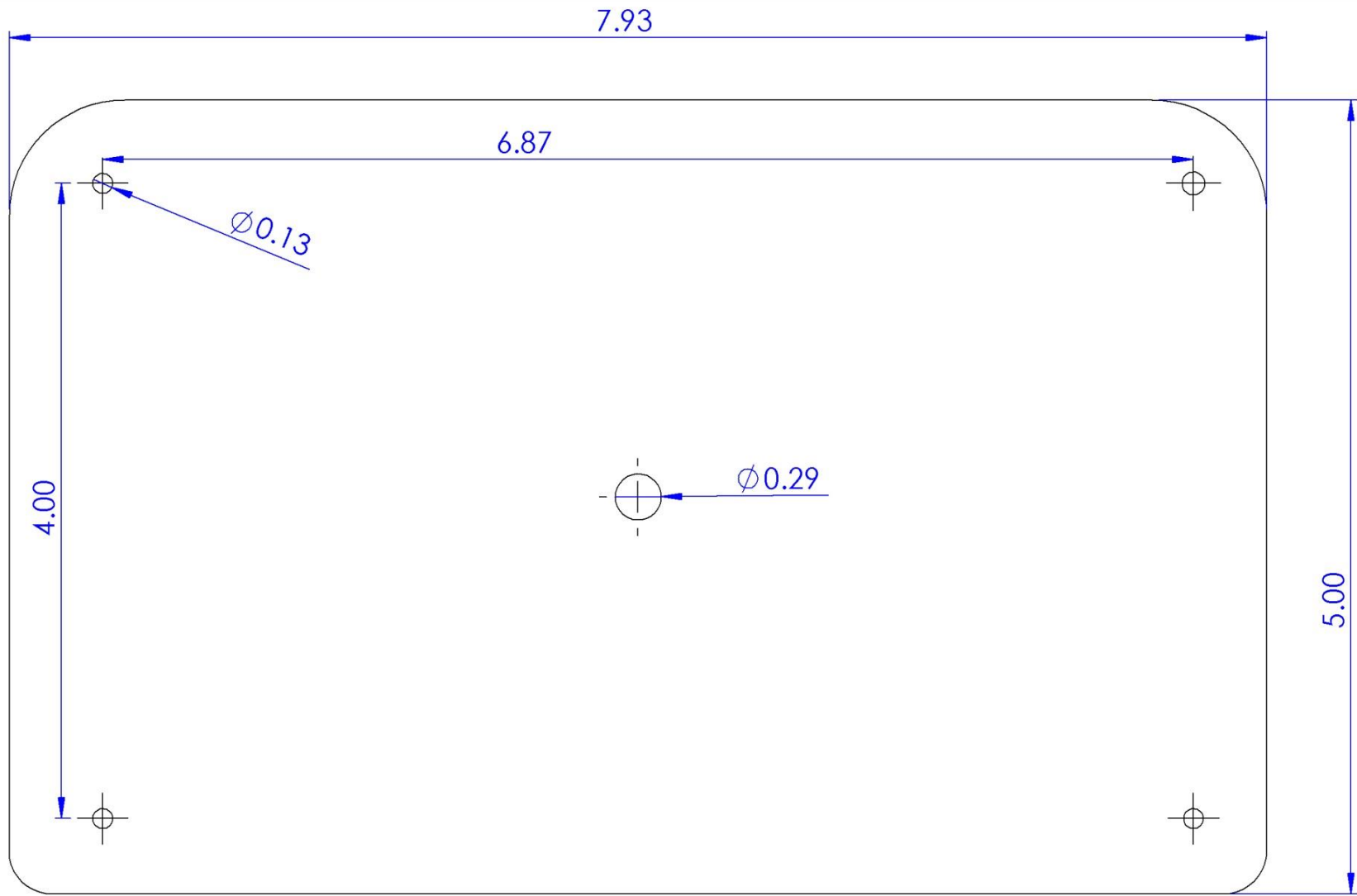

Verify the size of this print against dimensions given before use!

Altronics Inc		
TITLE:		
PowerQuest LCD Mounting Template		
SIZE	DWG. NO.	REV
A	1	1.0
SCALE: 1:1	WEIGHT:	SHEET 1 OF 1